

Cable Management Kit Assembly Model CM-F-ID

1. At the base of the robot (Zone D), begin by installing the base bracket (1) using the M8 X 1.25 X 16MM bolts and M8 flat washers provided.
2. Attach the J1 Bracket (1) in Zone C to the robot with the M10 X 1.5 X 20 MM SHCS bolts and washers provided.
3. Attach the J2 Bracket (1) in Zone B to the robot with the M10 X 1.5 X 20 MM SHCS bolts and washers provided.
4. Attach the J3 Bracket (1) in Zone A to the robot with the M10 X 1.5 X 20 MM SHCS bolts and washers provided.
5. Insert cable hose into the preinstalled clamp blocks on each of the brackets. Install the top half of the clamp blocks to secure the hose in place. Tighten mounting bolts in place to bring clamp blocks together.
6. Attach the power cable lug to the connection point on the wire feeder (location may vary based on model).
7. Attach the other end of the cable to the positive power cable connection point at the base of the robot (Zone D).

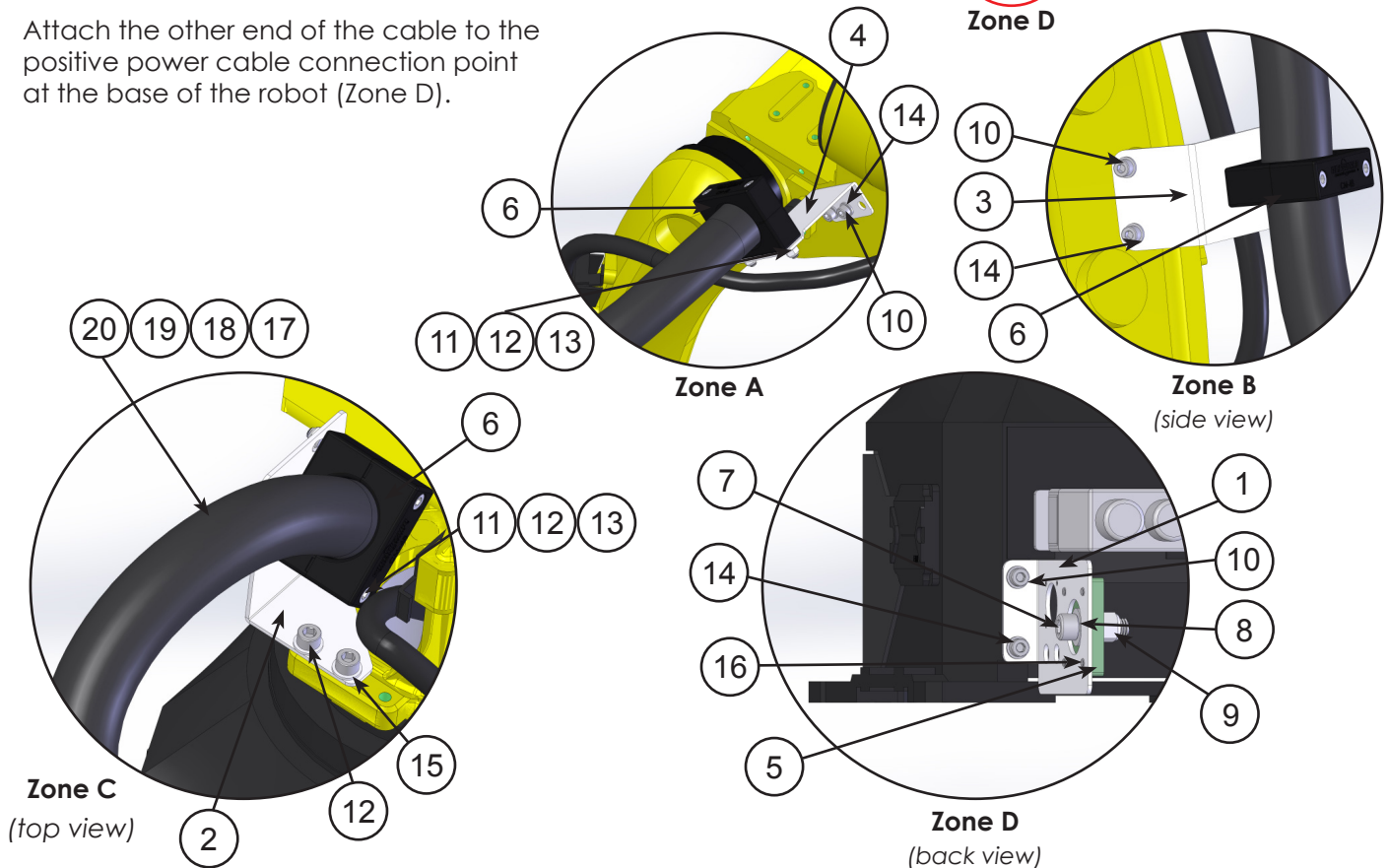

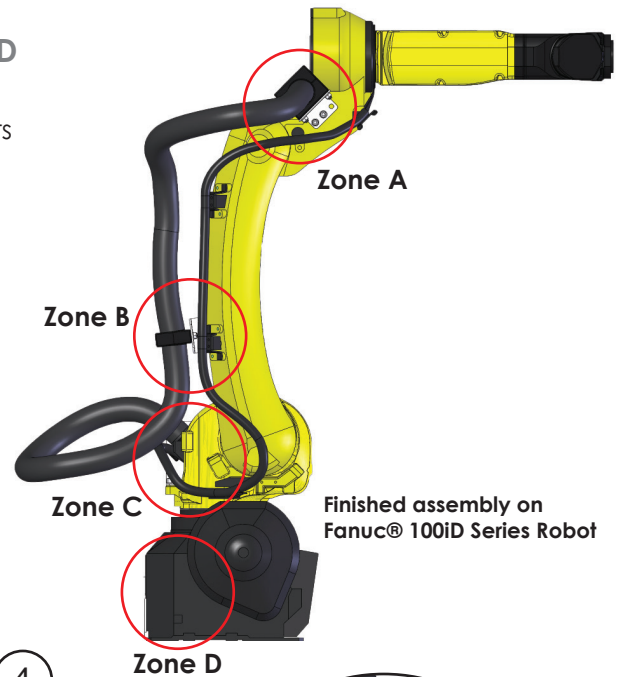
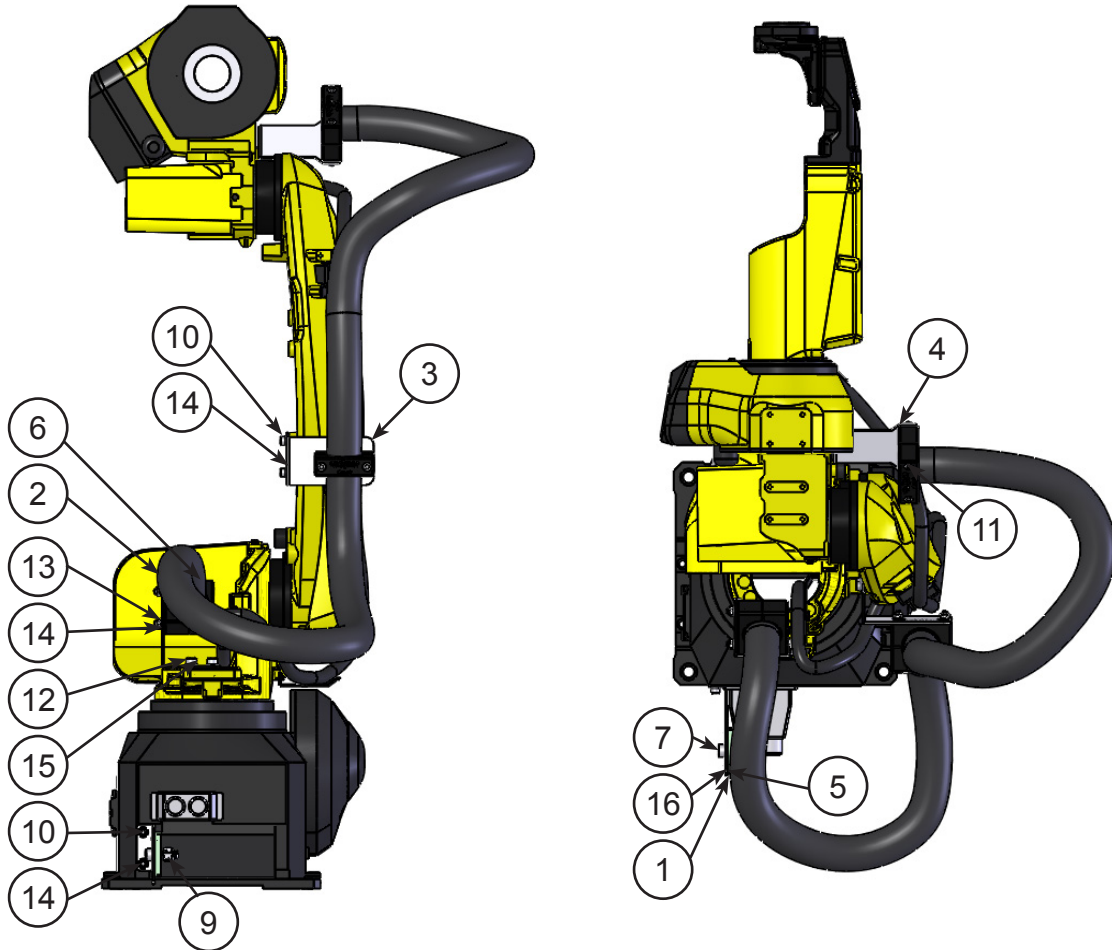

ZONE	ITEM NO.	PART NUMBER	DESCRIPTION	QTY.
D	1	CM-F-ID-2	BASE BRACKET	1
A	2	CM-F-ID-3	J1 BRACKET	1
B	3	CM-F-ID-4	J2 ARM BRACKET	1
A	4	CM-F-ID-5	J3 BRACKET	1
D	5	CM-F-3-4-2	BASE INSULATOR PLATE	1
C, B	6	ASSY CM-48	CONDUIT HOLDER	3
D	7	39656	M12 X 1.75 X 40 SHCS	1
D	8	33086	M12 FLAT WASHER	1
D	9	40171	M12 X 1.75 NYLOC NUT	1
A, D	10	35932	M8 X 1.25 X 16MM	6
A, B, C	11	39614	M8 X 1.25 X 85MM SHCS	6
C	12	39617	M10 X 1.5 X 20 SHCS	2
A, B, C	13	40163	M8 NYLOC INSERT LOCK NUT	6
A, B, C	14	40357	M8 FLAT WASHER	12
C	15	40358	10MM FLAT WASHER ZINC	2
D	16	41389	M6 X 14 FHCS	4
A, B, C, D	17	DWC30	3/0 WELDING CABLE 600 VOLT	9'
A, B, C, D	18	LEN07030	3/0 - 4/0 CABLE LUG	2
A, B, C, D	19	EPS-200-1	4" SHRINK TUBE	2
A, B, C, D	20	3146K320	CONTINUOUS FLEX CONDUIT	6'

REV. 1/10/18

Cable Management Kit Component Parts List for CM-F-ID

IMAGE	PART NUMBER	DESCRIPTION	QTY
	23409	1/2" - 13 X 1.50 SHCS	1
	33086	1/2" FLAT WASHER ZINC PLATED	1
	37030	1/2 - 13 NYLOC NUT ZINC PLATED	1
	35932	M8-1.25 X40 FHCS ZINC PLATED	6
	39617	M10 X 1.5 X 20 SHCS	2
	40357	M8 FLAT WASHER ZINC PLATED	6
	40358	10MM FLAT WASHER ZINC PLATED	2